

Carefully read the instructions prior to start building the kit!

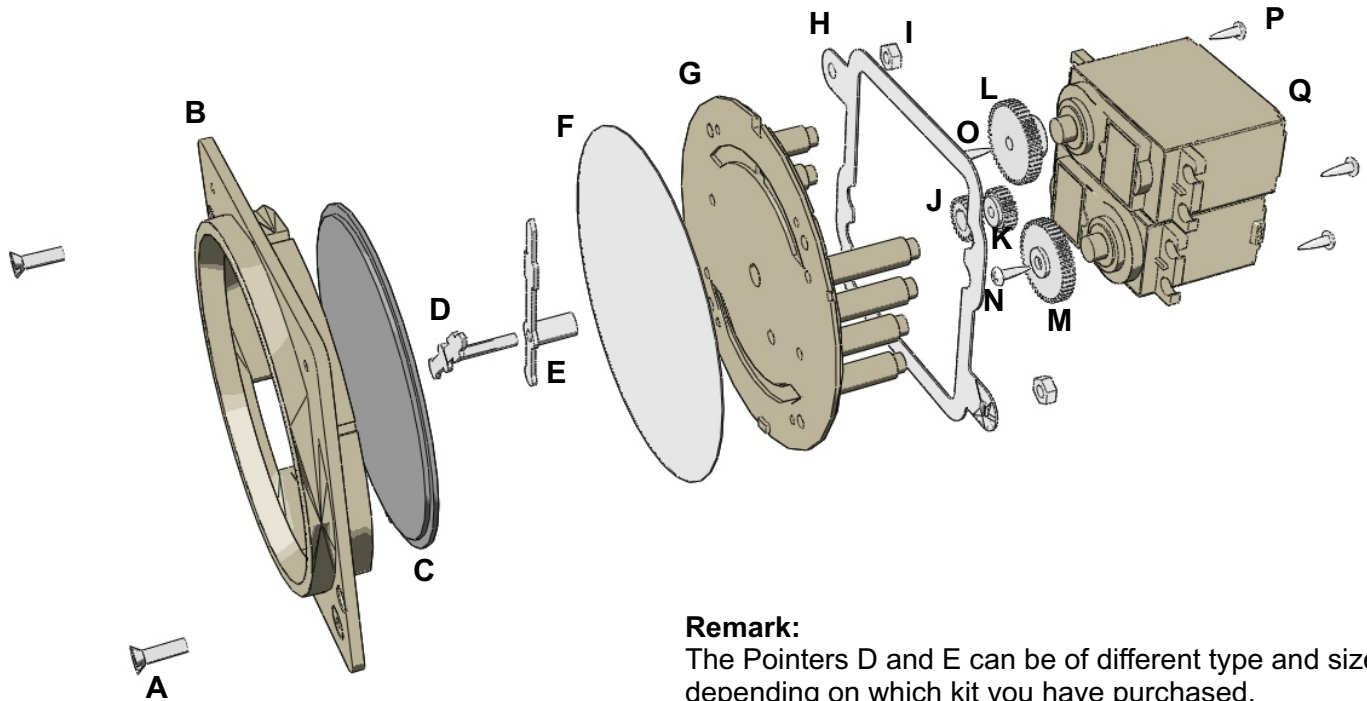

### Remark:

The Pointers D and E can be of different type and size, depending on which kit you have purchased.

**Remark:** When constructing a single pointer instrument, cut off the lower pointer from the shaft and use the shaft as bearing for the upper pointer. Always mount both gear wheels, even when only one pointer is used.

### Construction kit "Large Instrument with Dual or Single Pointer"

Your kit contains all the necessary components - except for servomotor(s) when you purchased the most economic kit - for building a large gauge with single or dual pointer.

### Difficulty level

This product can be constructed without technical expertise. Care and accuracy are of utmost importance.

No glue is needed to construct this instrument. All parts fit perfectly and where necessary the friction between different parts is enough to construct the gauge.

### What else do you need?

One or two type HS322 or equivalent servomotor is required to make the instrument fully functional. This product can be ordered separately or from any retailer of model kits. Additionally you will need some simple tools, such as a small star-shaped screwdriver and a hobby knife.

### General hints

Be very careful when using the hobby knife! You can easily hurt yourself when handling sharp objects!

### Preparations before beginning construction

Check if all components are included. During packing, the contents of the construction kit have been inspected several times. Nothing should be missing.

Use the hobby knife to remove any irregularities. Be careful when using a sharp hobby knife!

### Warranty

Construction kits come without a warranty!

### List of components

- A - Set of self M3 screws to mount the Front Ring onto the metal mounting frame H
- B - Front Ring
- C - Optical
- D - Pointer 1 \*
- E - Pointer 2 \*
- F - Face plate
- G - Mounting Plate (cut to size, see following pages)
- H - Mounting frame (stainless steel)
- I - Nut

- J - Upper Center Gear Wheel (mounted by pressing onto the shaft of the pointer)
- K - Lower Center Gear Wheel (mounted by pressing onto the shaft of the pointer)
- L - Upper Servo Gear Wheel (mounted by the original servo screw)
- M - Lower Servo Gear Wheel (mounted by the original servo screw)
- N - Servo Gear Screw (original servo screw)
- O - Servo Gear Screw (original servo screw)
- P - Self Tapping Screws for servo mount.
- Q - Servo(s). Not included in kit w/o servos.

1\*) The type of pointer depends on the kit ordered.

2\*) The type of pointer depends on the kit ordered.

This instrument is designed to connect directly to the Multi Controller by means of the servo 3-pin connector. When the servo lead is too short, you can order a servo extension cable of 50 cm (20") or 100 cm. (40").

Lighting can be applied to this instrument by ordering the special filament lamp and by

## Pointer legends

Depending on the type of gauge purchased, a double set of pointer legends (transfers) is supplied. Only one set needs to be applied. The second set is just for spare purposes when something goes wrong while applying them.

**Note: if the type of gauge purchased has no need for legends, the transfers are not included in the kit!**

### How to apply

The transfers are printed mirror wise and are self sticking.

1. Cut the transfer paper into 2 or 4 pcs. - depending on the type of transfer - in such a way that you have one (1) transfer for one (1) pointer.

2. Remove the protection sheet from the transfer.

Do not touch the self sticking surface of the transfer.

3. Carefully position the pointer in such a way that it is exactly aligned on the transfer. The small indication lines will help you to align the pointer.

4. Press the pointer onto the sticking surface of the transfer.

Do not move the transfer and wet the transfer paper with normal water until it comes loose from the pointer by itself (put the pointer into a cup or deep plate).

5. Let the pointer dry in a safe place before mounting it onto the gauge.

**Warning:** The legend can easily be damaged by touching it with other objects as long as the pointer is not mounted in the gauge.

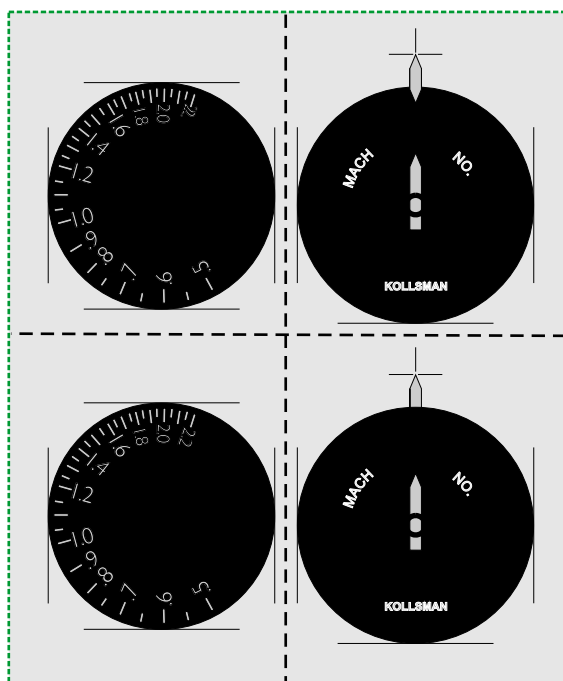
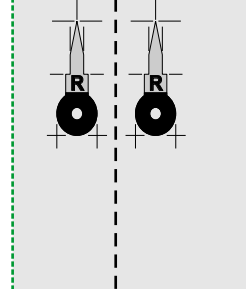
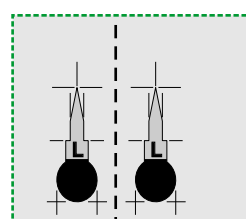
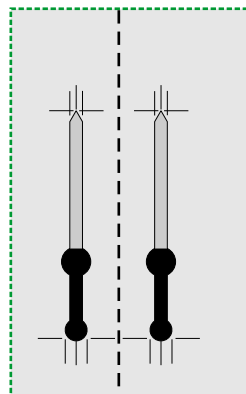
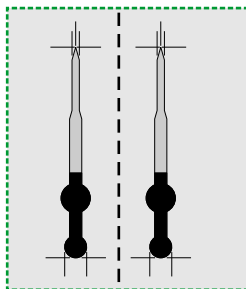
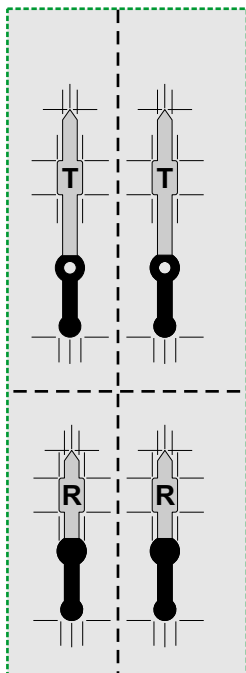

**Note:** the pictures of the transfers on this page show the complete pointer. The transfers do not necessary include all colors as shown here. It depends on the original color of the pointer (black, white, or transparent) which colors are present on the transfer)

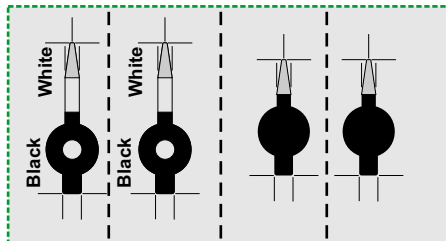
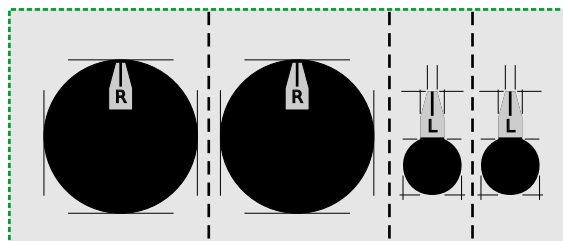
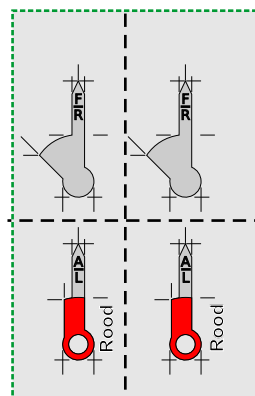

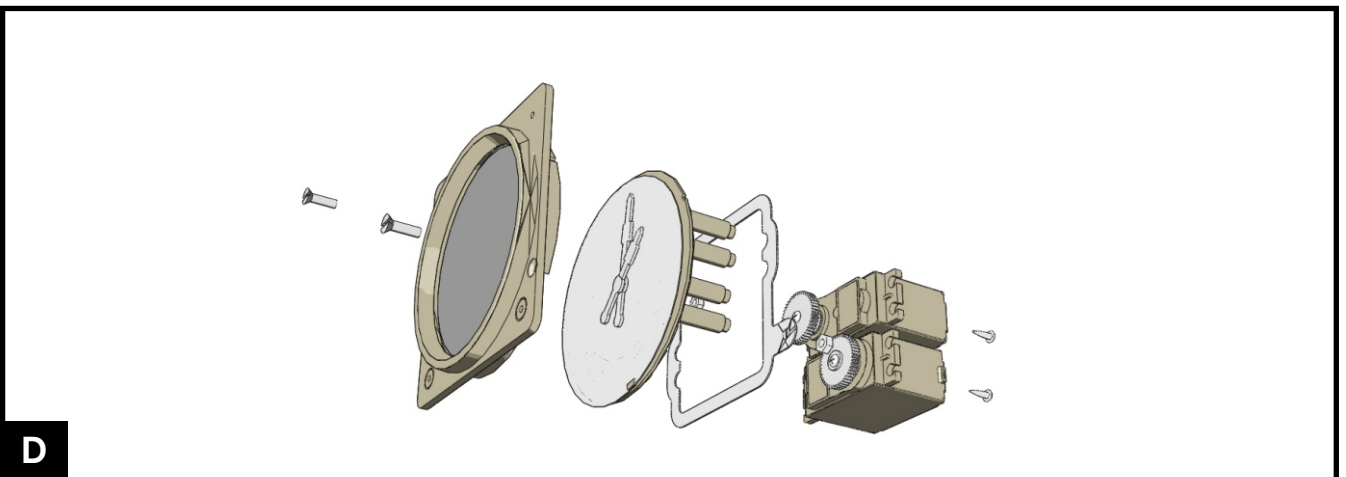
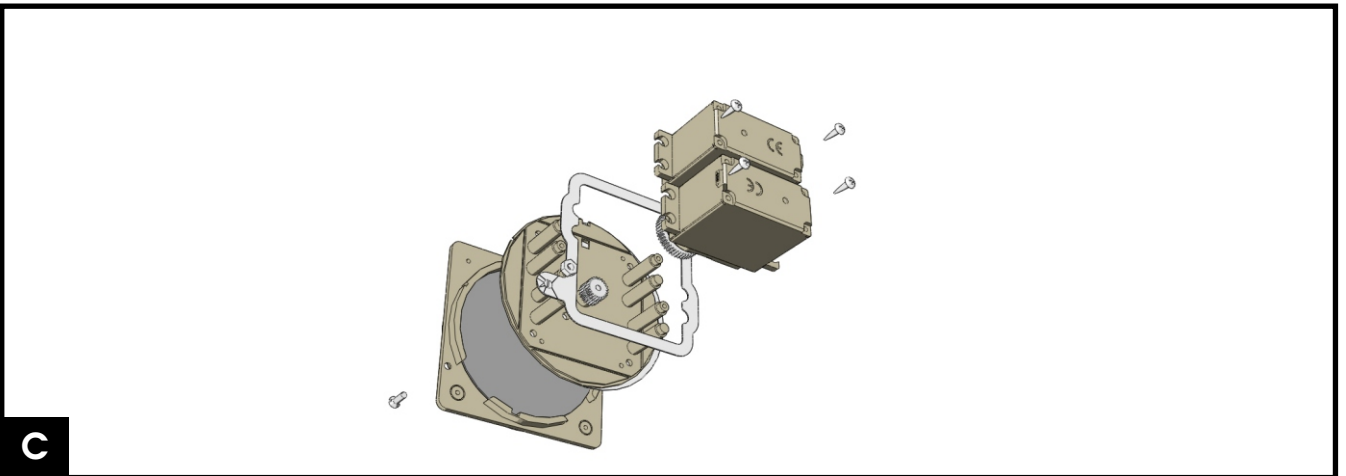
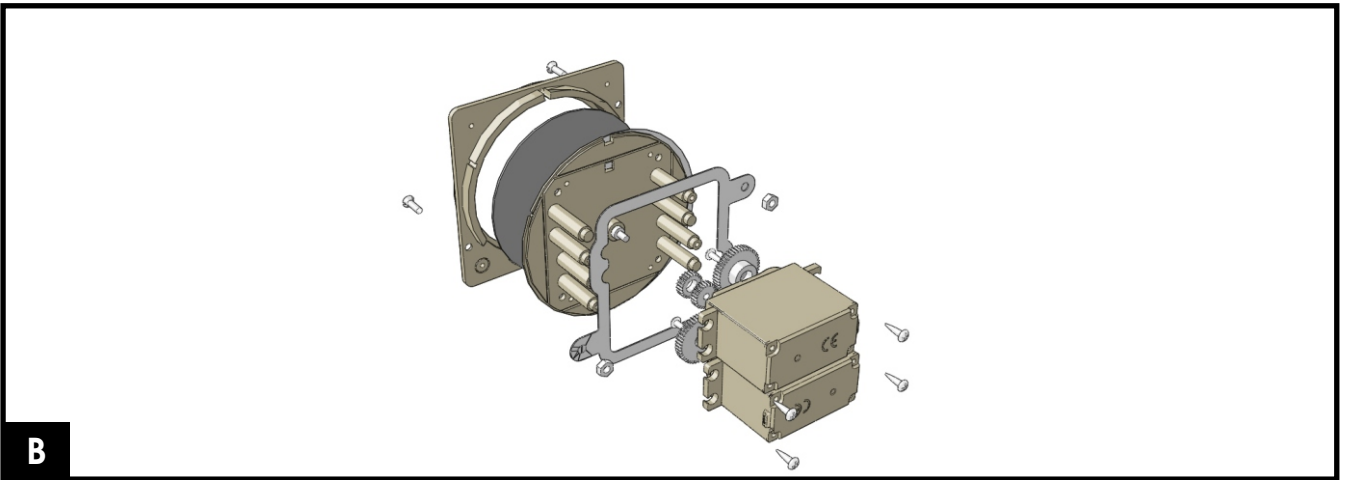
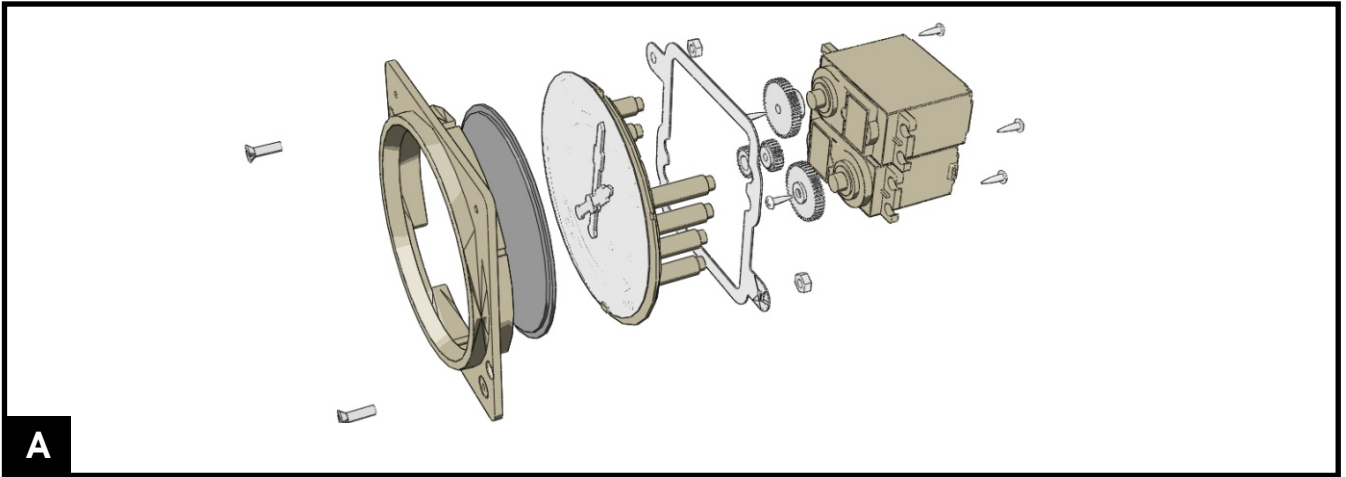

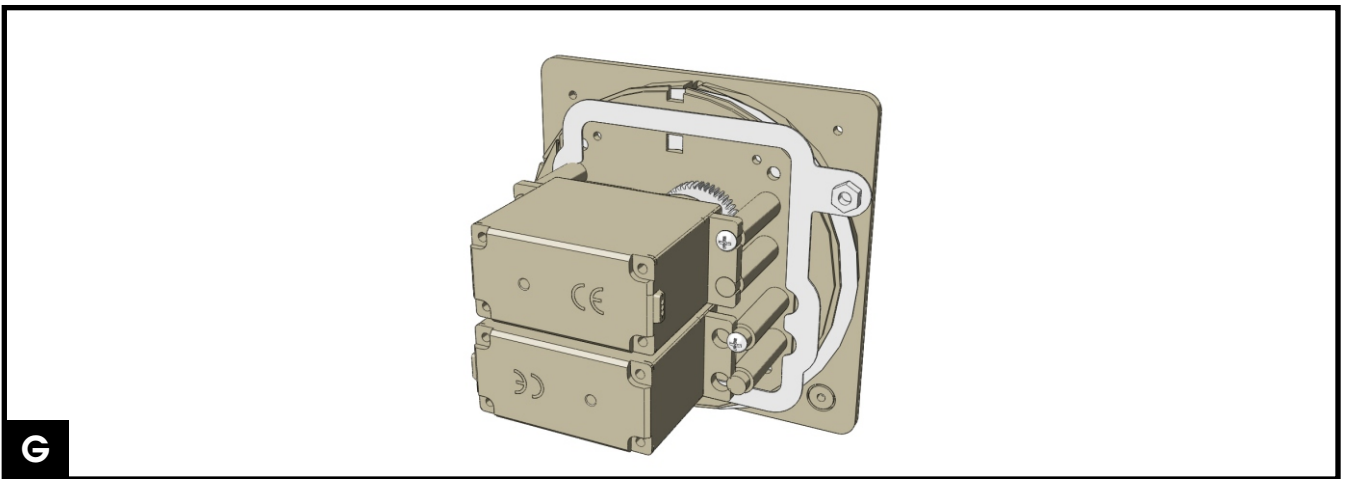
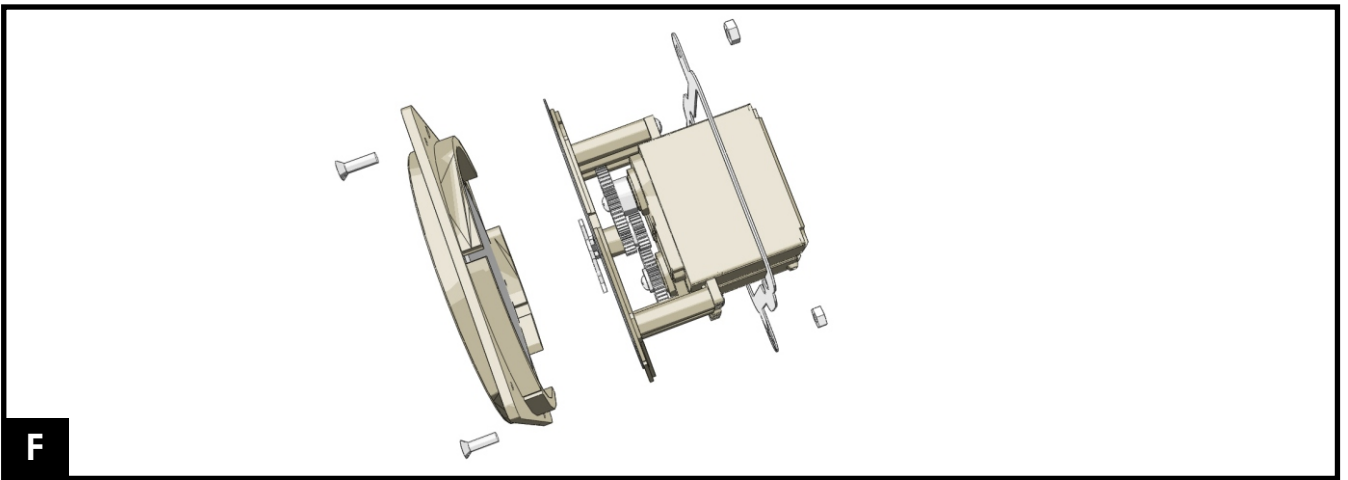
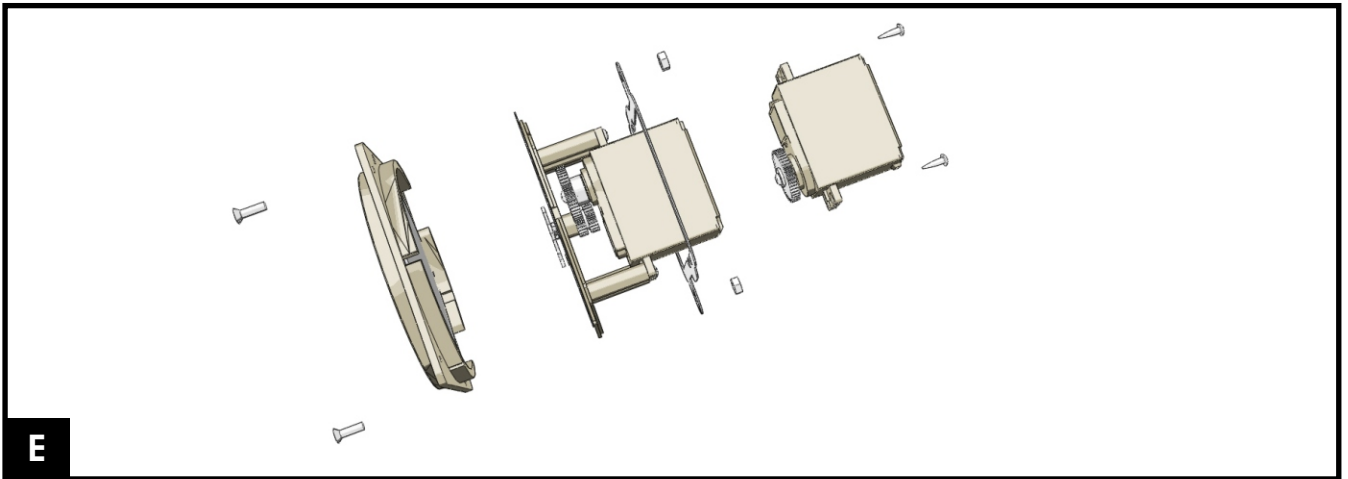

***Note: The stainless steel frame fits only in one position!***