



TRC USB 32-Input Controller functionally described

The TRC USB 32-Input Controller is a so-called HID device and is recognized under Windows as a standard input device. Up to 15 of the same boards can be connected to your PC.

Therefore you need no special drivers or setup software.

Once recognized by Windows, you will find the TRC USB 32-Input Controller in the section "Game Controllers" in your Windows area.

There is no need for calibration.

The 32 different inputs (either switches with a permanent position or pushbuttons can be connected) can be assigned to a function within Microsoft Flight Simulator, via the menu Options/Controls/Assignments.

Setting the identification

The TRC USB 32-Input Controller has a 4 position DIL Switch. Using a certain combination of this switch, you can give the USB 32-Input Controller a unique

Identification (ID) which allows you to connect up to 16 TRC USB 32-Input Controllers, with each their own DIL switch setting.

The ID will change from 00 to 15 depending on the setting of the DIL switch. For Windows to recognize a change in the DIL switch setting, the device must be shortly removed from the USB connection.

The table for the DIL switch is easy. De count is digital. This means that each of the switch is representing a certain value when set. 0 (zero) is a valid number!

These values are 1, 2, 4, 8. This means that when the first and the second DIL switch is "ON", the read out value is 03. When all switches are "ON" the read out value is 15. When all switches are "OFF" the read out value is 00.

To set the dil switches to a certain value (for example 11), just switch on 1, 2 and 8.

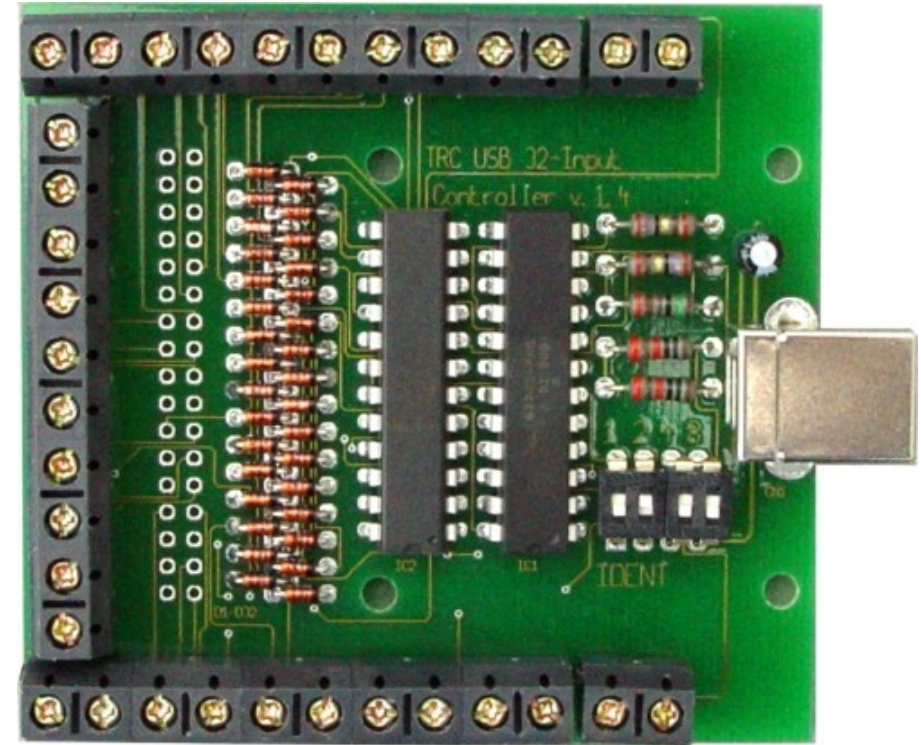

How to connect the switches/pushbuttons

You can connect up to 32 switches or pushbuttons to the inputs. The microcontroller reads out these 32 inputs in 2 different sections.

The first group of inputs 1-15 need to be connected to a switch or pushbutton, while the other side of these switches or pushbuttons need all to be together connected to input 1. The second group of inputs 16 to 32 need to be connected to a switch or pushbutton, while the other side of these switches or pushbuttons need all to be together connected to input 2.

See the explaining figure "how to connect the inputs".



Partlist

- IC2 = CY63742/43
- IC3 = 74HCT154
- IC4 = DIL Switch 4-position
- R1 = 27 Ohm (red, violet, black)
- R2 = 27 Ohm (red, violet, black)
- R3 = 1K5 Ohm (brown, green, red)
- R4 = 10 K Ohm (brown, black, orange)
- R5 = 10 K Ohm (brown, black, orange)
- C1 = 1 μ F (polarity!)
- D1-D32 = Diode 1N4148 (polarity!)
- KL1/KL3 = 10 pin connector
- KL4/KL5 = 2 pin connector
- K1 = USB Connector type B
- K2 = not used

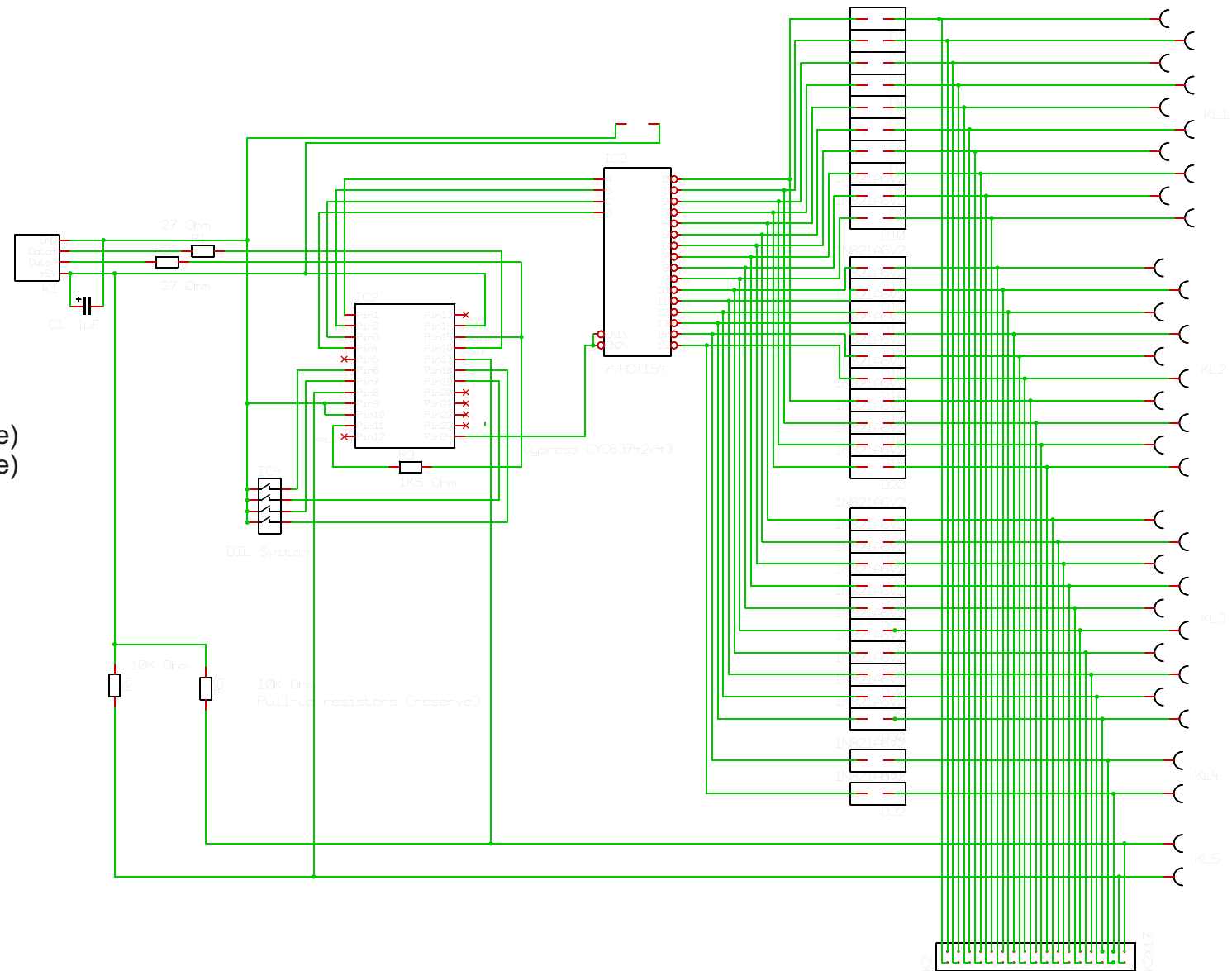



Partslist

- IC2 = CY63742/43
- IC3 = 74HCT154
- IC4 = DIL Switch 4-position
- R1 = 27 Ohm (red, violet, black)
- R2 = 27 Ohm (red, violet, black)
- R3 = 1K5 Ohm (brown, green, red)
- R4 = 10 K Ohm (brown, black, orange)
- R5 = 10 K Ohm (brown, black, orange)
- C1 = 1 μ F (polarity!)
- D1-D32 = Diode 1N4148 (polarity!)
- KL1/KL3 = 10 pin connector
- KL4/KL5 = 2 pin connector
- K1 = USB Connector type B
- K2 = not used

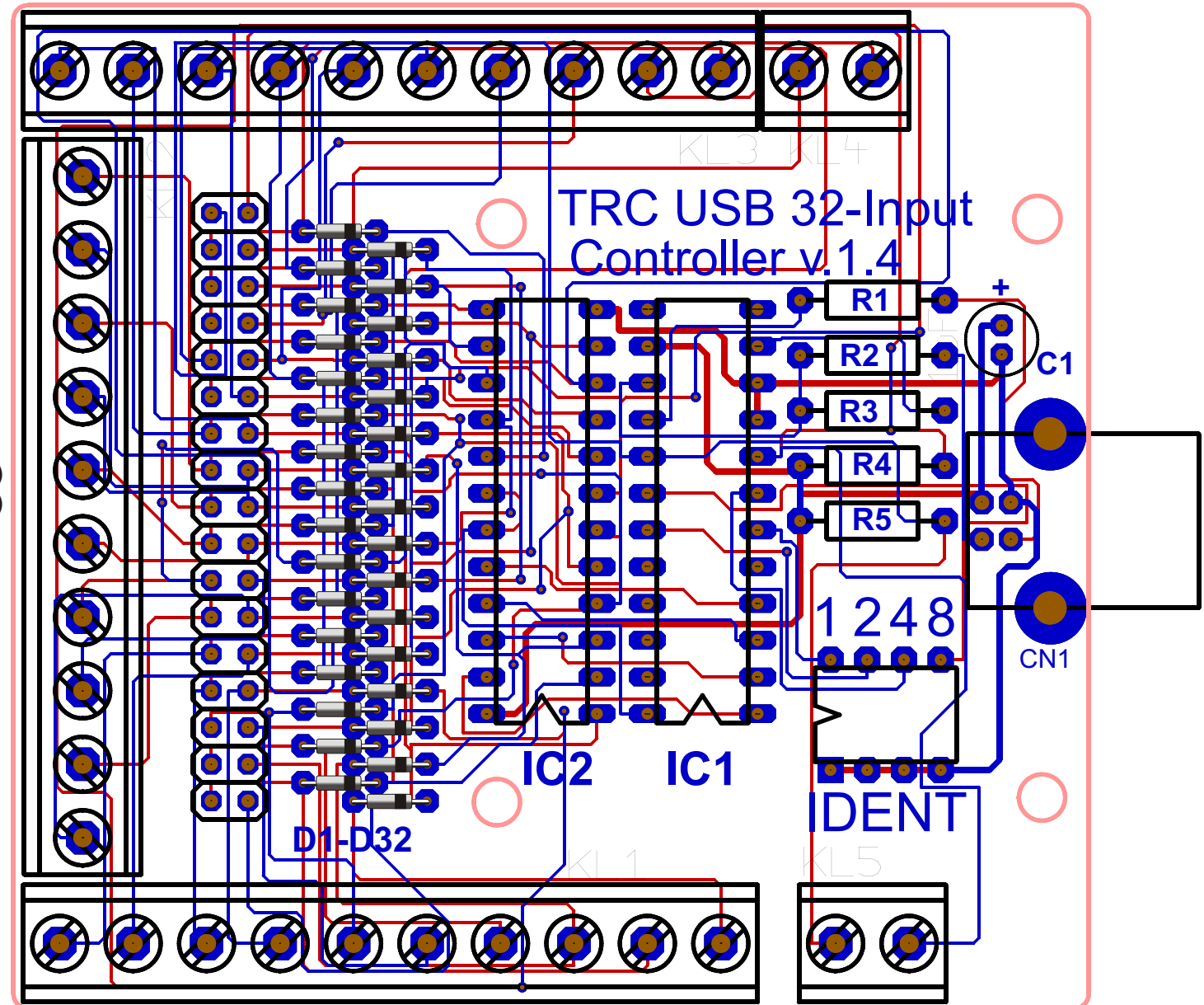



Connection Table

Header Connector *)	Screw Connector	Signal
1	KL1-1	1
2	KL1-2	2
3	KL1-3	3
4	KL1-4	4
5	KL1-5	5
6	KL1-6	6
7	KL1-7	7
8	KL1-8	8
9	KL1-9	9
10	KL1-10	10
11	KL2-1	11
12	KL2-2	12
13	KL2-3	13
14	KL2-4	14
15	KL2-5	15
16	KL2-6	16
17	KL2-7	17
18	KL2-8	18
19	KL2-9	19
20	KL2-10	20
21	KL3-1	21
22	KL3-2	22
23	KL3-3	23
24	KL3-4	24
25	KL3-5	25
26	KL3-6	26
27	KL3-7	27
28	KL3-8	28
29	KL3-9	29
30	KL3-10	30
31	KL4-2	31
32	KL4-1	32
33	KL5-1	Input 1
34	KL5-2	Input 2

Switches or Pusbuttons

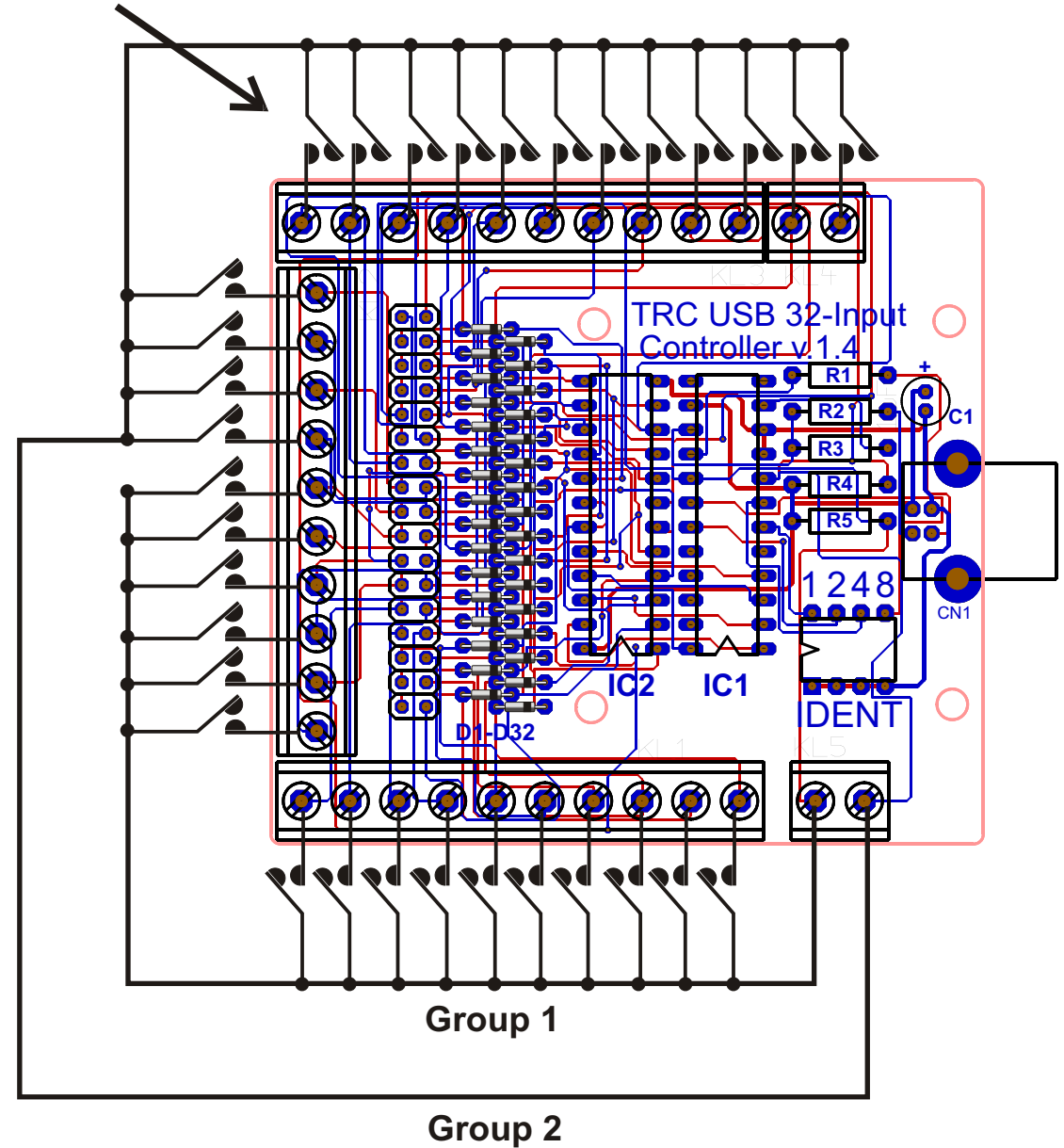

*) The header connector is not included in the product.